



Doughty Engineering Ltd

Zenith Mk3 Winch Stand



Operating Manual

www.doughty-engineering.co.uk



Table of Contents

Revision History	2
Contact Details	2
Purpose	3
Introduction	3
Safety Precautions	4
Assembly	6
Operation	6
Maintenance and Cleaning	7
Parts Illustrations	8
Declaration of Conformity	10

Revision History

Issue	Amendment	Date
1	New document	27-01-09
2	Introduction modified	18-06-09

Contact Details

Doughty Engineering Ltd
Crow Arch Lane
Ringwood
Hants
BH24 1NZ
England
Telephone +44 (0) 1425 478961
Fax +44 (0) 1425 474481

www.doughty-engineering.co.uk
sales@doughty-engineering.co.uk

www.doughty-engineering.co.uk



This manual applies to the following products:

Part No.	Description	Height
T55580	Zenith 520 Roller Base	5M
T55582	Zenith 520 Turnbuckle Base	5M
T55590	Zenith 620 Roller Base	6M
T55592	Zenith 620 Turnbuckle Base	6M

Purpose

The Zenith Mark 3, 520 & 620 stands are a four section winch stand with a safe working load of 200Kg. Zenith stands are supplied with a 28mm (1-1/8") receiver accepting standard TV spigots. Accordingly these stands are suitable for use with small trusses, loudspeakers, lighting equipment etc. The Zenith Mk 3 is available in two styles, consisting of turnbuckle or roller base arrangements.

Caution: Before using please read, note and retain these operating and safety instructions

Introduction

To ensure reliable operating of the Zenith range of stands, please read these instructions before use.

The Zenith stands are subjected to stringent tests prior to manufacture and each stand is inspected through the manufacturing and assembly processes. **In order to maintain this guarantee of function and safety, whenever any spare parts are required, these must be supplied by Doughty Engineering Ltd.** The user forfeits all rights to claim if parts are not of original specification, or if the stand is modified in any way.

Due to our policy of continuous improvement, Doughty Engineering Limited reserve the right to amend or alter the specifications of the product at any time without prior notice. When requiring spares or service, please quote the model type and year of manufacture as indicated on the stand.

Type	Part No.	Min Load	Max Load	Closed Height	Extended Height	Unit Weight
520R	T55580	15Kg	200Kg	1815mm	5123mm	93.5Kg
520T	T55582	15Kg	200Kg	1692mm	4984mm	76.0Kg
620R	T55590	15Kg	200Kg	2048mm	6238mm	99.5Kg
620T	T55592	15Kg	200Kg	1925mm	6100mm	82.0Kg

The stand is manufactured from mild steel (DIN 2394) box sections throughout, and primarily comprises 4 telescopic mast sections, steel stabiliser legs and struts. The cable used is of DIN 15020 2350N/mm² (6mm/7x19) grade and must be replaced with this specification.



The stand is available in two configurations. The roller configuration (T55580/T55590) features a 4 castor base plate, with removable legs which slot into the base plate when the stand is in use. When the stand is not in use the legs can be removed and slotted into their transport position parallel to the main body of the stand (figure 4).

The turnbuckle base (T55582/T55592) comprises of a flat base plate with all four legs permanently attached. The legs rotate outwards from their transport position until they contact the ground, and retract into their transport position (figure 5). There are two transport wheels fitted to the reverse side of the stand base as illustrated, to aid transportation.

Safety Precautions

The Zenith stands provide easy and smooth lifting and lowering. The user must determine if the product has the necessary characteristics to fulfil the required application.

Excluded applications:

- Not tested for construction hoists
- Not approved for lifting persons
- Not approved for motorised use

Automatic mechanical brake: The TÜV approved winch used on these stands is fitted with an automatic brake. The minimum load as marked on the stand should be met to ensure the brake performs correctly. For any matters relating to the winch, please refer to the winch operating instructions supplied.

Note: Do not apply oil or grease to the brake mechanism. The brake washers are pre-greased with pressure resistant grease.

Before loading, the stand must be placed on a suitably firm and level surface, with the stabiliser legs in place and in firm contact with the ground. Confirm that the mast section of the stand is vertical prior to use. A spirit level is located on the baseplate of the turnbuckle stand to assist.

The cable should be visually inspected at all accessible points for frays, cuts or kinks before the stand is used. If any defects are found then the stand should be removed from service until a suitable repair can be made. Do not attempt to use the stand with a damaged cable. Do not shorten the cable at the winch connection.

The winch handle must not be removed from the stand while a load is fitted, as this will disengage the brake and allow the load to drop. The minimum load as listed on the table above and on the stand must be met to ensure correct braking action on the winch.



If using the stand in open air, ensure the stand is firmly supported by guy ropes to allow for weather conditions.

The stand should not be moved with a load attached, whether the mast is extended or retracted. Do not lean ladders or stairways onto the stand. The stand is not to be used for lifting or supporting personnel. The stand should only be used for vertical lifting, do not attempt to operate the stand off vertical. All loads must be evenly distributed.



Assembly

Roller Base:

1. Manoeuvre the stand to the desired location, ensuring the base of the stand is in contact with the supporting surface.
2. Remove the legs from their transport position.
3. Insert the leg into the base leg receiver (see figure 4), ensuring the adjustable foot is orientated to contact the supporting surface.
4. Turn the foot support to lower or raise the foot. The foot should be in firm contact with the supporting surface.
5. Repeat the above actions for all four legs.
6. Once the legs are secured the load may be attached to the stand by using a 28mm TV spigot. This must be secured in the receiver by the Tommy Bar provided (see figure 2).
7. To disassemble the stand prior to moving, perform the above actions in reverse order.

Turnbuckle Base:

1. Manoeuvre the stand to the desired location and raise the mast to the vertical, ensuring the base of the stand is in contact with the supporting surface.
2. Release the legs from their transport position by removing the R clip and locking pin (see figure 5).
3. Rotate the legs about the pivot point, ensuring the pivot foot is orientated to contact the supporting surface, and lock the turnbuckle into the leg support bracket with the locking pin. Ensure the R clip retains the locking pin.
4. Repeat the above actions for all four legs.
5. Adjust the turnbuckles to centralise the spirit level and ensure the mast is vertical. The base of the stand must remain in direct contact with the ground.
6. Once the mast section is vertical and the legs are secured the load may be attached to the stand by using a 28mm TV spigot. This must be secured in the receiver by the Tommy Bar provided (see figure 2).
7. To disassemble the stand prior to moving, perform the above actions in reverse order.

Operation

Lifting:

1. To start raising the stand, pull and rotate the upper locking pin (figure 1) to locate in the raise position (see figure 1) and rotate the winch handle (figure 2-8) clockwise, as indicated on the body of the winch.
2. Once located in the raising position, the locking pin will operate on a ratchet when the winch handle is turned and the stand is raised.
3. Continue winding the handle until the mast either stops moving (top of stroke), or the desired height is achieved.
4. To release the next mast section, pull and rotate the locking pin to locate it in the raise position (see figure 1).
5. Repeat steps 3 and 4 for the remaining section.



6. Ensure that all locking pins are engaged on the mast sections by rotating the winch handle counter-clockwise until the masts stop descending. Rotate the handle clockwise to remove any slack from the wire after checking.

Lowering:

1. To start lowering the load, ensure that the cable is tight and supporting the load.
2. Disengage the locking pin from the mast section by pulling and rotating the pin into the raise position (see figure 1).
3. Rotate the winch handle (see figure 3) counter-clockwise as indicated on the winch body to lower the mast section.
4. When the mast section reaches its base position, pull and rotate the locking pin into the lock position to secure the mast (see figure 1).
5. Repeat the above actions for the remaining mast sections until the stand is fully retracted.
6. The load may now be removed from the stand and the stand folded ready for transport.

Before attempting to move the stand, ensure the load is removed, and the locking pins (figure 2-7) retain the mast sections.

Maintenance and Cleaning

The cable must be inspected before each use of the stand, as detailed above (section 3), and also given at least an annual inspection to ensure that there are no kinks, deformations, single strand breakage or cuts in the wire. Defective wires must be replaced before the stand is returned to service.

The winch and stand are checked and lubricated during assembly, it is recommended that the gear drive and handle threads be lubricated, and oil applied to the bearings on the drum hub and the drive shaft. **On no account should oil or grease be applied to the brake mechanism.**

The mast locking strips and locking pins should be checked at least annually to ensure secure locking of the stand in its raised position. Particular attention should be paid to the leading edges of the pin and strip, and to the return spring.

The Zenith stand should be inspected annually by trained personnel. If spares are required, these should be obtained from Doughty Engineering Limited. Please quote the reference number from the drawings included, the year of manufacture and serial number as marked on the stand. If parts not of original manufacture are used, or if the stand is modified in any way, the user forfeits all rights to claim.

Parts Illustrations

Figure 1

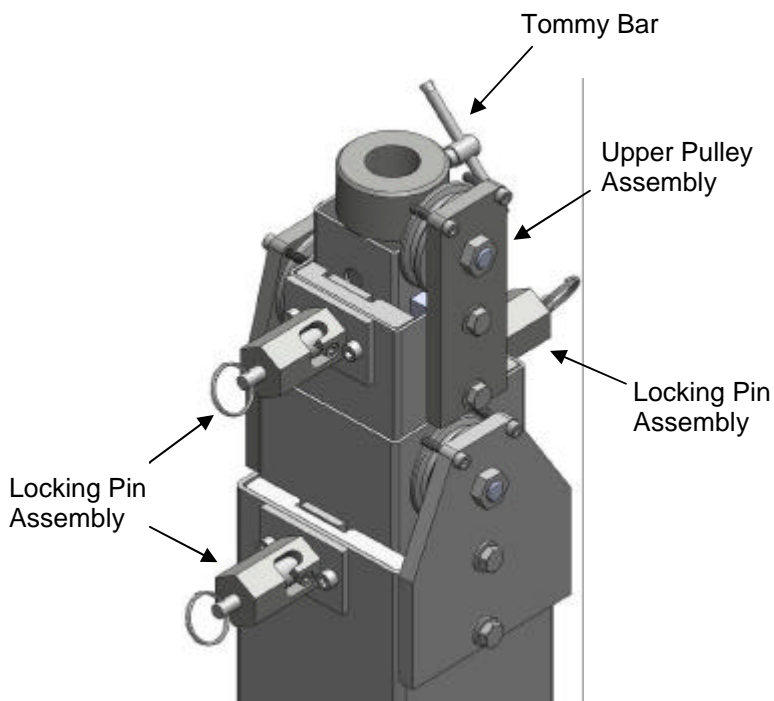
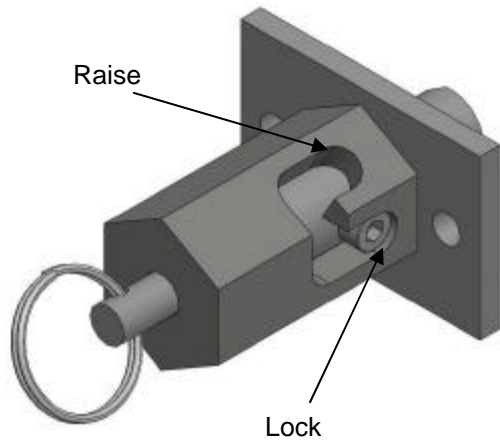

Figure 2

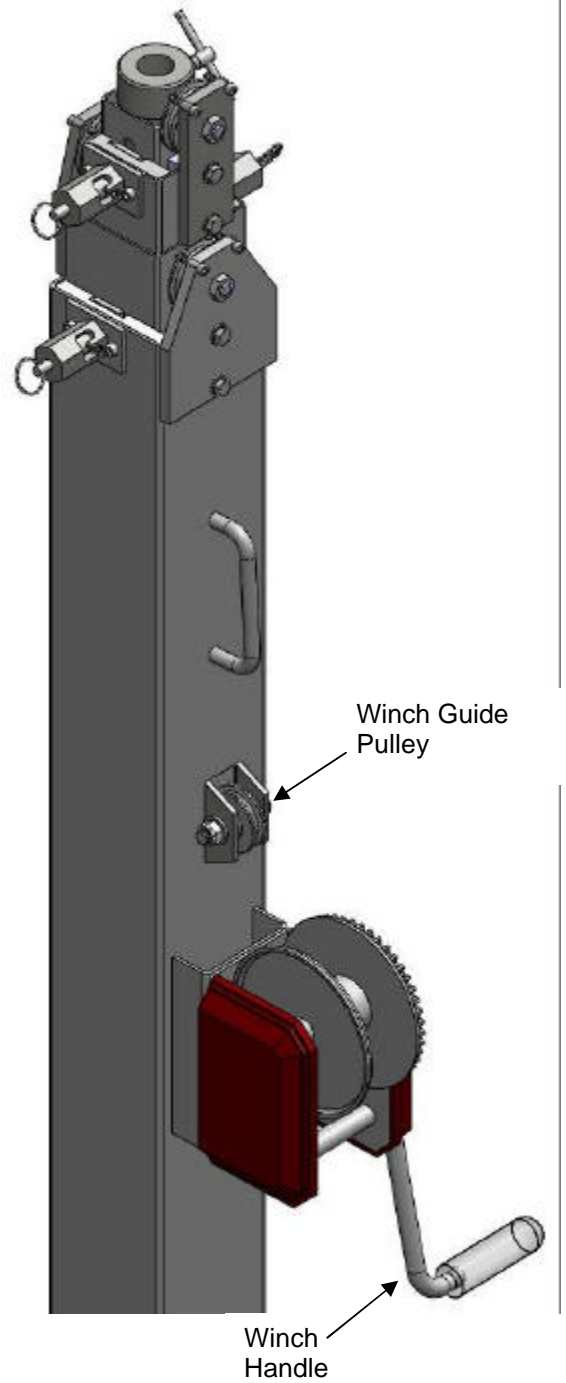

Figure 3

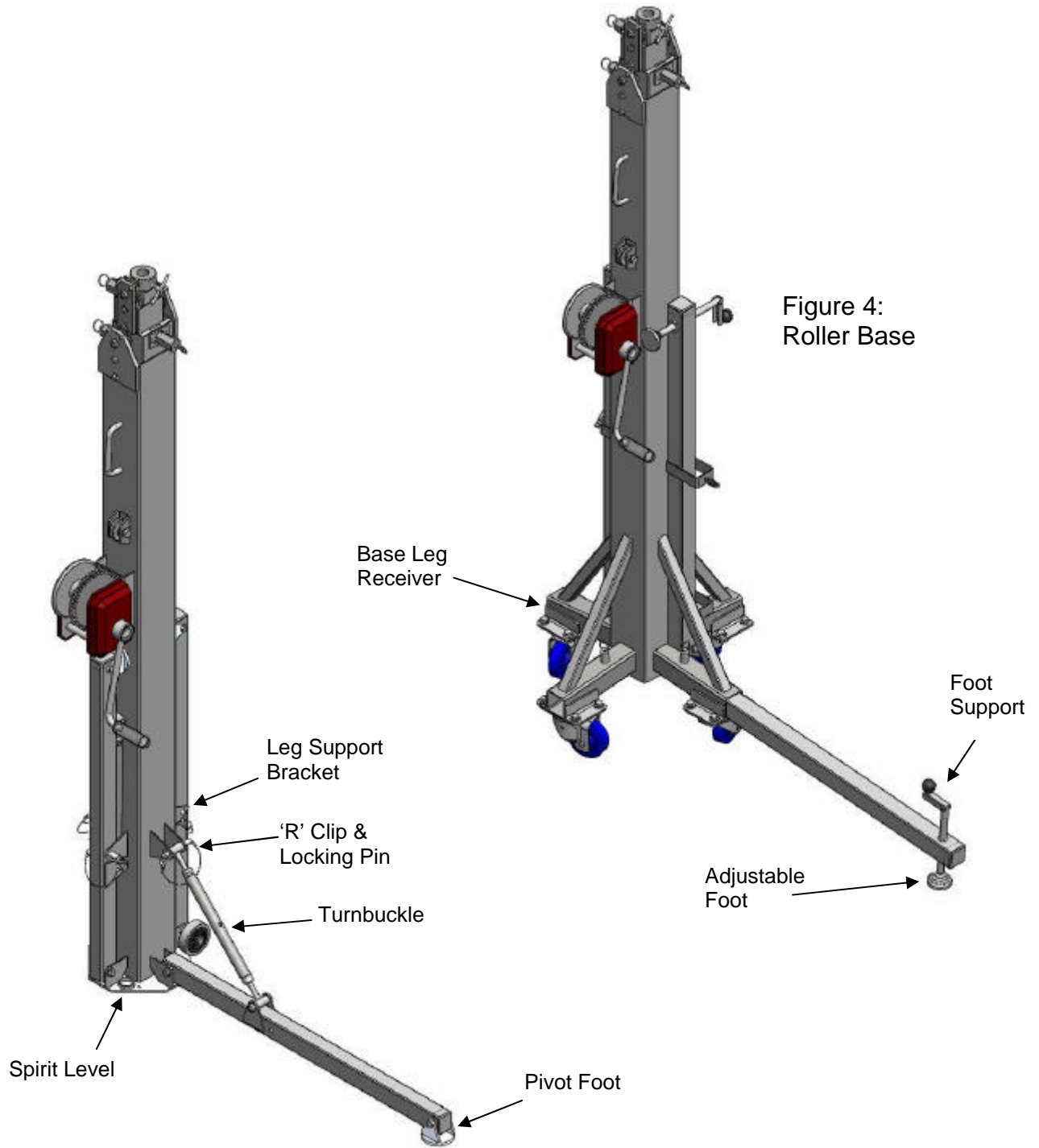

Figure 4:
Roller Base

Figure 5:
Turnbuckle Base



Declaration of Conformity

DECLARATION OF CONFORMITY.

According the EC Machinery Directive 89/392 EEC

Manufacturer's Name: Doughty Engineering Limited.

Manufacturer's Address: Crow Arch Lane.
Ringwood.
Hampshire.
BH24 1NZ.
England

Declares that the product:

Product Name: Zenith Mark 3.

Model Numbers: 520R, 520T, 620R, 620T

Accessories covered: Optional extended base plate.

Conforms to the following Product Specifications in their standard design when used for lifting and lowering loads as directed in the supplied instructions:

Safety: DIN 15560

Also as detailed in: EN 292 Part 1, EN 292 Part 2

Supplementary Information: The product herewith complies with the requirements of the Machinery Directive 89/392/EEC as amended by the Directives 91/368/EEC, 93/44/EEC, 93/68/EEC, 98/37/EC and carries the CE marking accordingly. GS symbols were awarded for the above types. Test certificate number: AL 00 04 20319 010. The units supplied conform to the tested types.

The product, when elevated and secured with locking pins as detailed, complies with VBG70 (GUV 6.15).

Ringwood, March, 2000

Nigel D Curtis, General Manager